



STG4158

Low voltage 0.6 Ω typ single SPDT switch with break-before-make feature and 15 kV ESD protection

Features

- Power-off and over-voltage protection
- Wide operating voltage range:
 V_{CC} (opr) = 1.65 to 4.5 V
- Low ON resistance $V_{IN} = 0$ V:
 - $R_{ON} = 0.85 \Omega$ (max) at $V_{CC} = 4.5$ V
- Latch-up performance exceeds 300 mA JESD 17
- ESD performance tested on (D pin)
 - 8 kV IEC-61000-4-2 ESD, contact discharge
 - 15 kV IEC-61000-4-2 ESD, air discharge
- ESD performance test on all other pins
 - 3 kV Human-Body-Model
 - 200 V machine model (IEC61340-3-2 level M2)
 - 1000 V charge-device model (JESD22 C101)

Description

The STG4158 is a high-speed CMOS low voltage single analog SPDT (single pole dual throw) switch or 2:1 multiplexer/ demultiplexer switch fabricated in silicon gate C²MOS technology. Designed to operate from 1.65 to 4.5 V, this device is ideal for portable applications.

It offers low ON resistance (0.6 Ω) at $V_{CC} = 4.5$ V (typical $T_A = 25$ °C). The SEL input threshold is compatible to 1.8 V, and provides control to the switches.

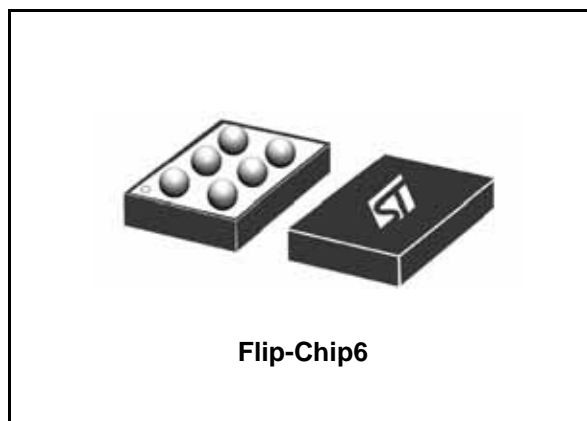

The switch S1 is ON (connected to common port D) when the SEL input is held high and OFF (high impedance state exists between the two ports) when SEL is held low. The switch S2 is ON (connected to common port D) when the SEL input is held low and OFF (high impedance state exists between the two ports) when SEL is held high.

The SEL input has an integrated weak pull-down resistor to prevent SEL signal from floating. For low power consumption, the SEL input must be grounded.

Power-off and over-voltage protection

The STG4158 features power-off and over-voltage protection, enabling the device to be isolated during voltage fault events.

Table 1. Device summary

Order code	Package	Packing
STG4158BJR	Flip-Chip6	Tape and reel

Contents

1	Logic diagram	3
2	Maximum rating	5
3	Electrical characteristics	6
4	Application information	10
5	Test circuits	12
6	Package mechanical data	16
7	Revision history	20

1 Logic diagram

Figure 1. Functional diagram

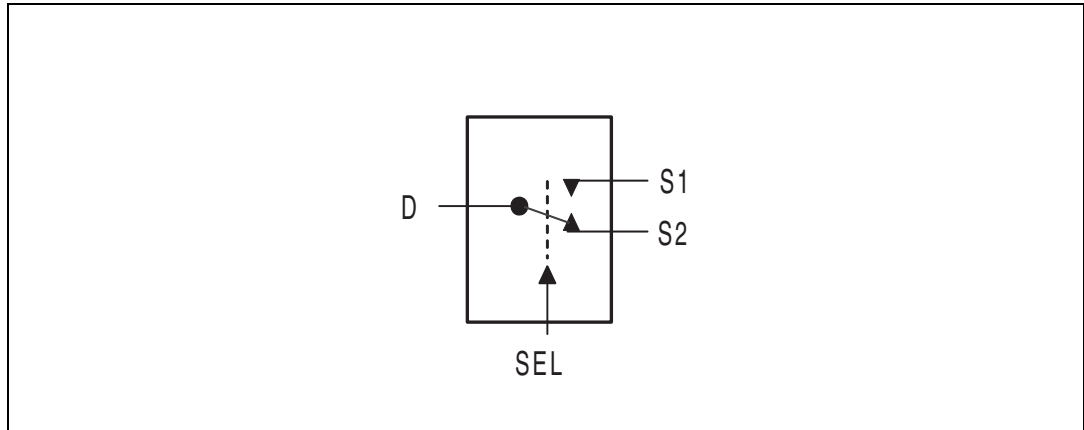
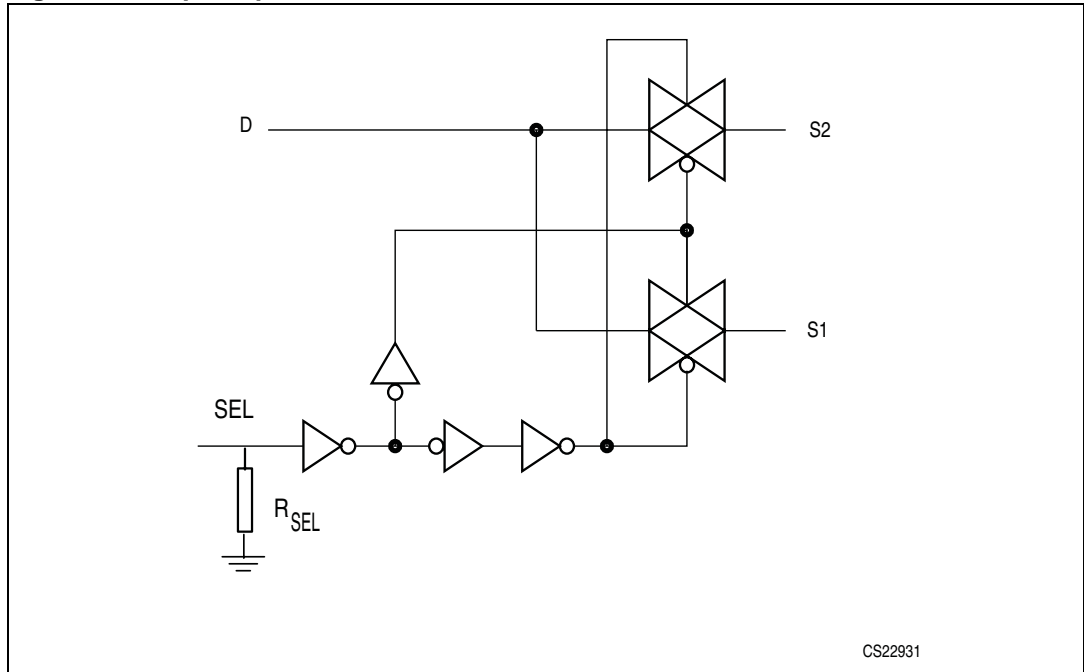

Figure 2. Input equivalent circuit



CS22931

Table 2. Truth table

SEL	Switch S1	Switch S2
H	ON	OFF ⁽¹⁾
L	OFF ⁽¹⁾	ON

1. High impedance

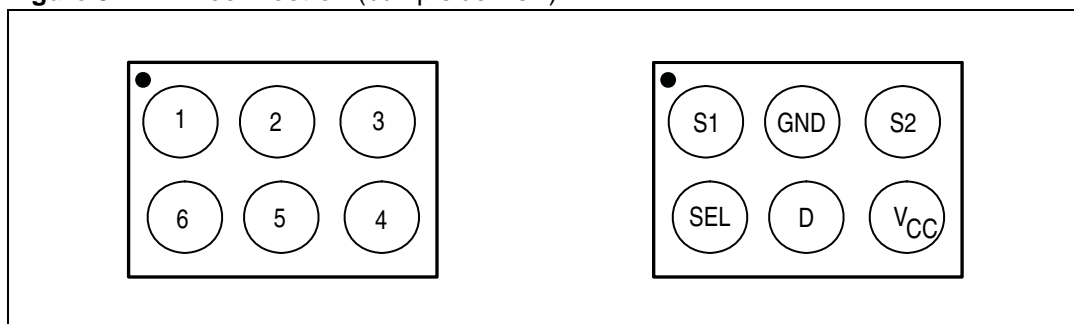
Figure 3. Pin connection (bump side view)**Table 3. Pin description**

Flip-Chip	Symbol	Name and function
1, 3	S1, S2	Independent channels
5	D	Common channel
6	SEL	Control
4	V _{CC}	Positive supply voltage
2	GND	Ground (0V)

2 Maximum rating

Stressing the device above the rating listed in the “absolute maximum ratings” table may cause permanent damage to the device. These are stress ratings only and operation of the device at these or any other conditions above those indicated in the operating sections of this specification is not implied. Exposure to absolute maximum rating conditions for extended periods may affect device reliability. Refer also to the STMicroelectronics SURE Program and other relevant quality documents.

Table 4. Absolute maximum ratings

Symbol	Parameter	Value	Unit
V_{CC}	Supply voltage	-0.5 to 5.5	V
V_I	DC input voltage	-0.5 to $V_{CC} + 0.5$	V
V_{IC}	DC control input voltage	-0.5 to 5.5	V
V_O	DC output voltage	-0.5 to $V_{CC} + 0.5$	V
I_{IKC}	DC input diode current on control pin ($V_{SEL} < 0\text{ V}$)	- 50	mA
I_{IK}	DC input diode current ($V_{SEL} < 0\text{ V}$)	± 50	mA
I_{OK}	DC output diode current	± 20	mA
I_O	DC output current	± 300	mA
I_{OP}	DC output current peak (pulse at 1ms, 10% duty cycle)	± 500	mA
I_{CC} or I_{GND}	DC V_{CC} or ground current	± 100	mA
P_D	Power dissipation at $T_A = 70^\circ\text{C}$ ⁽¹⁾	500	mW
T_{stg}	Storage temperature	-65 to 150	$^\circ\text{C}$
T_L	Lead temperature (10 sec)	260	$^\circ\text{C}$

1. Derate above 70°C by 18.5 mW/C

Table 5. Recommended operating conditions

Symbol	Parameter	Value	Unit
V_{CC}	Supply voltage	1.65 to 4.5	V
V_I	Input voltage	0 to V_{CC}	V
V_{IC}	Control input voltage	0 to V_{CC}	V
V_O	Output voltage	0 to V_{CC}	V
T_{op}	Operating temperature	-40 to 85	$^\circ\text{C}$
dt/dv	Input rise and fall time control input	$V_{CC} = 1.65$ to 2.7 V	0 to 20
		$V_{CC} = 3.0$ to 4.5 V	0 to 10

3 Electrical characteristics

Table 6. DC specifications

Symbol	Parameter	V _{CC} (V)	Test condition	Value					Unit
				T _A = 25 °C			-40 to 85 °C		
				Min	Typ	Max	Min	Max	
V _{IH}	High level input voltage	1.65 – 1.95		0.9			0.9		V
		2.25 – 2.7		0.9			0.9		
		3.0 – 4.3		1.0			1.0		
		4.5		1.1			1.1		
V _{IL}	Low level input voltage	1.65 – 1.95					0.6	0.6	V
		2.25 – 2.7					0.6	0.6	
		3.0 – 4.3					0.7	0.7	
		4.5					0.7	0.7	
R _{ON}	ON resistance	1.65 – 2.20	V _S = 0 V to V _{CC} I _S = 100 mA		2.0			3.0	Ω
		2.25 – 3.6			0.9			1.3	
		3.7 – 4.5			0.6			0.85	
ΔR _{ON}	ON resistance match between channels (1)	1.65 – 2.20	V _S = 0 V to V _{CC} I _S = 100 mA		40			400	mΩ
		2.25 – 3.6			10			100	
		3.7 – 4.5			10			100	
R _{FLAT}	ON resistance flatness (2)	1.65 – 2.20	V _S = 0 V to V _{CC} I _S = 100 mA		1.2				Ω
		2.25 – 3.6			0.3			0.6	
		3.7 – 4.5			0.2			0.4	
R _{SEL}	SEL pull-down resistance	1.65 – 4.5			5000				kΩ
I _{OFF}	Sn OFF state leakage current	1.65 – 4.5	V _S = 0, V _D = V _{CC} V _S = V _{CC} , V _D = 0	-30		30	-300	300	nA
I _{ON}	Sn ON state leakage current	1.65 – 4.5	V _S = 0 to V _{CC} V _D = open	-20		20	-200	200	nA

Table 6. DC specifications (continued)

Symbol	Parameter	V _{CC} (V)	Test condition	Value					Unit
				T _A = 25 °C			-40 to 85 °C		
				Min	Typ	Max	Min	Max	
I _D	D ON state leakage current	1.65 – 4.5	V _S = open V _D = 0 to V _{CC}	-30		30	-300	300	nA
		Floating	V _D = 0 - 4.5		10			25	μA
		0 – 0.5	V _D = 0 - 4.5		10			25	μA
		V _{CC} > 0.5	V _D ≥ V _{CC} + 0.4		10			25	μA
I _S	S ON state leakage current	1.65 – 4.5	V _S = 0 to V _{CC} V _D = open	-30		30	-300	300	nA
		Floating	V _S = 0 - 4.5		5			15	μA
		0 – 0.5	V _S = 0 - 4.5		5			15	μA
		V _{CC} > 0.5	V _S ≥ V _{CC} + 0.4		5			15	μA
I _{CC}	Quiescent supply current	2.5	V _{SEL} = V _{CC}		5.6			10	μA
		4.5			9			20	μA
		1.65 – 4.5	V _{SEL} = GND		0.05			0.1	μA
I _{SEL}	SEL leakage current	1.65 – 4.5	V _{SEL} = GND		0.1			1.0	μA
		2.5	V _{SEL} = V _{CC}		0.5			1.0	μA
		4.5	V _{SEL} = V _{CC}		1.0			2.0	μA
I _{CCLV}	Quiescent supply current low voltage driving	4.5	V _{SEL} = 1.45 V		8			20	μA

Table 7. AC electrical characteristics ($C_L = 35 \text{ pF}$, $R_L = 50 \text{ } \Omega$, $t_r = t_f \leq 5 \text{ ns}$)

Symbol	Parameter	V_{CC} (V)	Test condition	Value					Unit
				$T_A = 25 \text{ } ^\circ\text{C}$			$-40 \text{ to } 85 \text{ } ^\circ\text{C}$		
				Min	Typ	Max	Min	Max	
t_{PLH} , t_{PHL}	Propagation delay	1.65 – 1.95			0.13				ns
		2.25 – 2.7			0.15				
		3.0 – 3.6			0.16				
		3.7 – 4.5			0.16				
t_{ON}	Turn on time	1.65 – 1.95	$V_S = V_{CC}$ $R_L = 50 \text{ } \Omega$ $C_L = 30 \text{ pF}$		112			160	ns
		2.25 – 2.7			64			86	
		3.0 – 3.6			43			58	
		3.7 – 4.5			28			38	
t_{OFF}	Turn off time	1.65 – 1.95	$V_S = V_{CC}$ $R_L = 50 \text{ } \Omega$ $C_L = 30 \text{ pF}$		14			20	ns
		2.25 – 2.7			13			18	
		3.0 – 3.6			13			18	
		3.7 – 4.5			13			18	
t_D	Break-before-make time delay	1.65 – 1.95	$C_L = 35 \text{ pF}$ $R_L = 50 \text{ } \Omega$ $V_S = V_{CC}/2$	10	86				ns
		2.25 – 2.7		10	56				
		3.0 – 3.6		5	31				
		3.7 – 4.5		5	25				
Q	Charge injection	1.65 – 1.95	$C_L = 1 \text{ nF}$ $V_{GEN} = 0 \text{ V}$		70				pC
		2.25 – 2.7			140				
		3.0 – 3.6			190				
		3.7 – 4.5			230				

Table 8. Analog switch characteristics ($C_L = 5 \text{ pF}$, $R_L = 50 \text{ } \Omega$, $T_A = 25 \text{ } ^\circ\text{C}$)

Symbol	Parameter	V_{CC} (V)	Test condition	Value					Unit
				$T_A = 25 \text{ } ^\circ\text{C}$			$-40 \text{ to } 85 \text{ } ^\circ\text{C}$		
				Min	Typ	Max	Min	Max	
OIRR	Off isolation ⁽¹⁾	1.65 – 4.5	$V_S = 1 \text{ V}_{RMS}$ $f = 100 \text{ kHz}$		-76				dB
			$V_S = 1 \text{ V}_{RMS}$ $f = 1 \text{ MHz}$		-55				
			$V_S = 1 \text{ V}_{RMS}$ $f = 5 \text{ MHz}$		-40				
Xtalk	Crosstalk	1.65 – 4.5	$V_S = 1 \text{ V}_{RMS}$ $f = 100 \text{ kHz}$		-81				dB
			$V_S = 1 \text{ V}_{RMS}$ $f = 1 \text{ MHz}$		-61				
			$V_S = 1 \text{ V}_{RMS}$ $f = 5 \text{ MHz}$		-48				
THD	Total harmonic distortion	2.3 – 4.5	$R_L = 600 \text{ } \Omega$ $C_L = 50 \text{ pF}$ $V_S = V_{CC} V_{PP}$ $f = 600 \text{ Hz to } 20 \text{ kHz}$		0.015				%
BW	-3dB bandwidth (switch ON)	1.65 – 4.5	$R_L = 50 \text{ } \Omega$		40				MHz
C_{SEL}	Control pin input capacitance	1.8 – 4.5	$V_L = V_{CC}$		30				pF
C_{Sn}	Sn port capacitance	1.8 – 4.5	$V_L = V_{CC}$		80				
C_D	D port capacitance when switch is enabled	1.8 – 4.5	$V_L = V_{CC}$		190				

1. OFF-isolation = $20 \log_{10} (V_D/V_S)$, V_D = output, V_S = input to off switch

4 Application information

Power-off and over-voltage protection

The STG4158 has two operation modes:

1. Normal operation mode
2. Isolation mode

In the normal operation mode, the switch functions as a normal SPDT, with the SEL pin that selects the switch to be either ON or OFF. Either S1 or S2 is connected to common channel D.

In the isolation mode, all the switches are OFF. S1 or S2 are isolated from common channel D. The S1, S2, D ports have a 1 M Ω impedance to ground.

The operation modes are made possible by special detection circuitry that detects the voltage level at D, S1 and S2 supplies. Depending on these voltage levels, the device goes into isolation mode or normal operation mode accordingly.

The isolation mode is a feature of the device that is useful during fault conditions that occur in the application environment.

Table 9. Voltage conditions

V_{CC}	$V_{D,S}$ (voltage at common port D, S1 or S2)	Voltage condition	Mode
Floating	0 – 4.5 V	All switches OFF S1, S2 and D are isolated from each other	Isolation
0 – 0.5 V	0 – 4.5 V	All switches OFF S1, S2, D are isolated from each other	Isolation
$V_{CC} > 0.5$	$V_{D,S} > V_{CC} + 0.4$	All switches OFF S1, S2 and D are isolated from each other	Isolation
1.65 – 4.5 V	0 – V_{CC}	Either S1 or S2 is connected to D, depending on SEL input	Normal

Figure 4. Voltage conditions

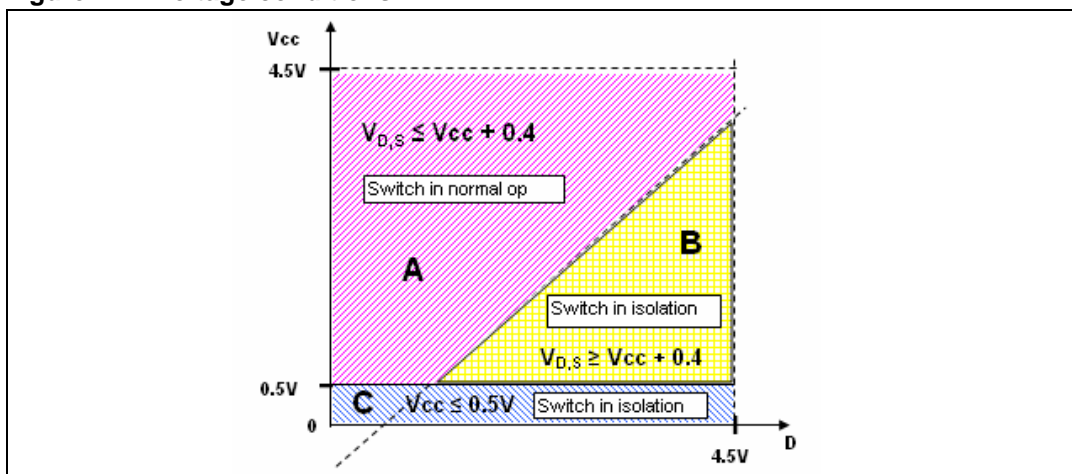

The SEL input has an integrated weak pull-down resistor R_{SEL} to prevent SEL signal from floating. For lower power consumption, the SEL input must be grounded.

5 Test circuits

Figure 5. ON resistance

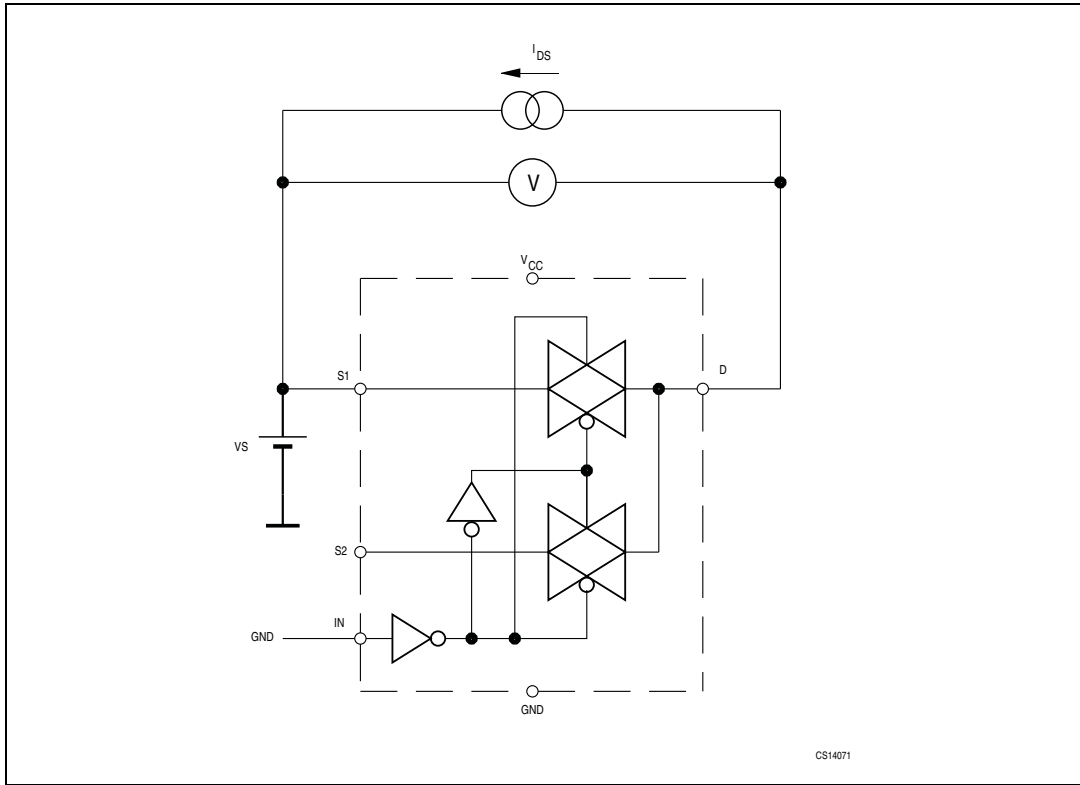

Figure 6. Bandwidth

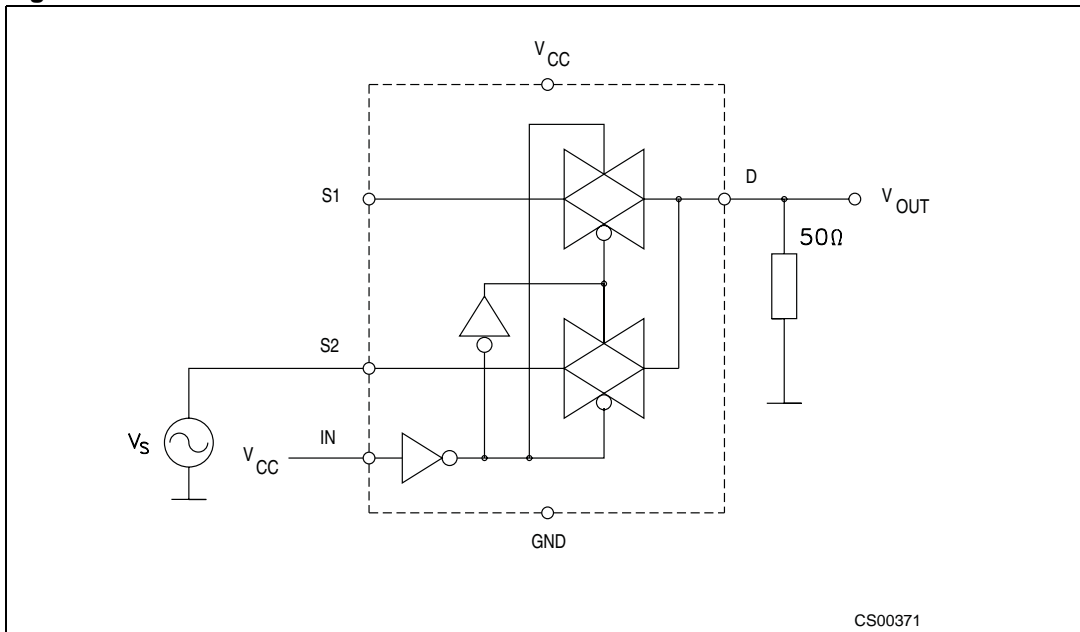

Figure 7. OFF leakage

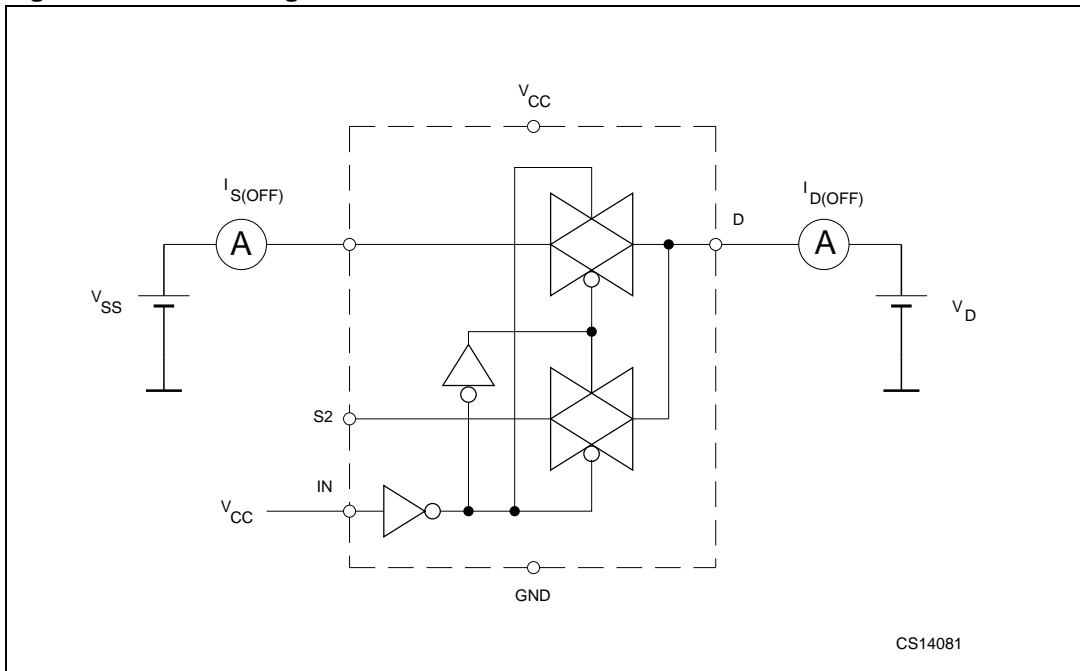

Figure 8. Channel-to-channel crosstalk

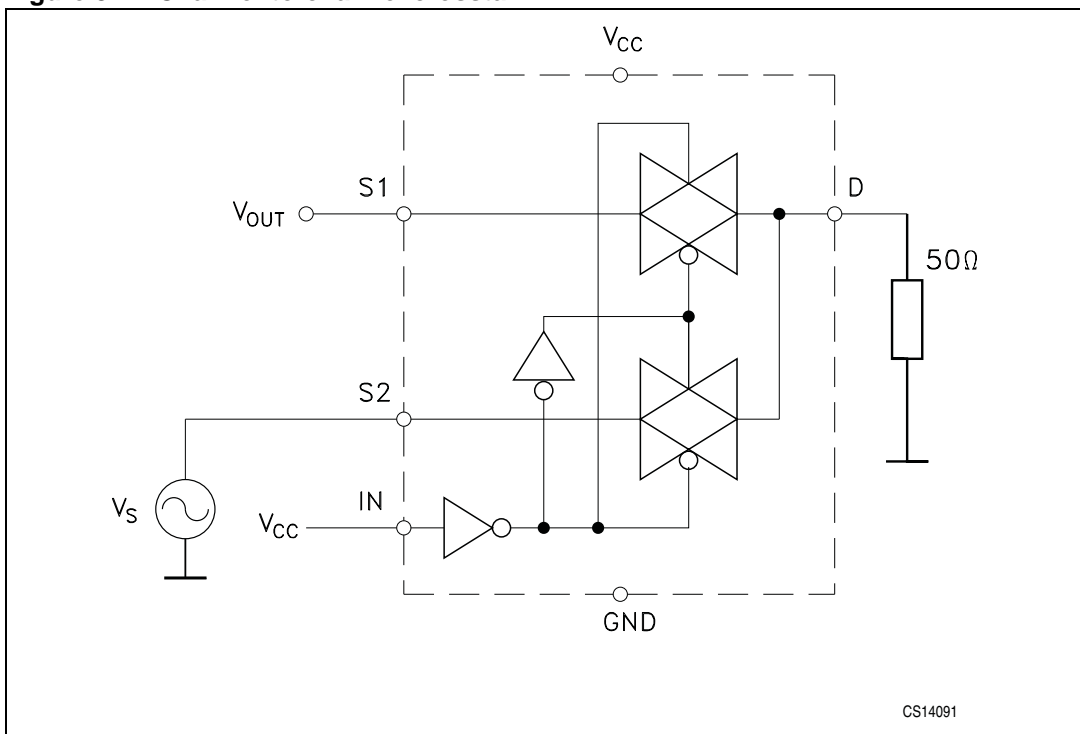

Figure 9. OFF isolation

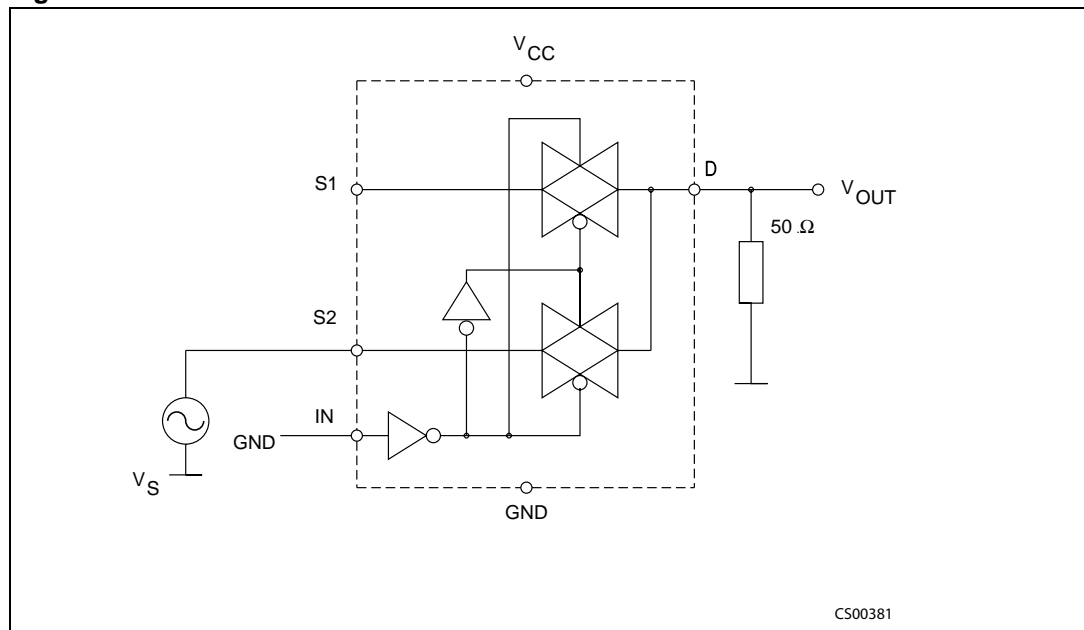
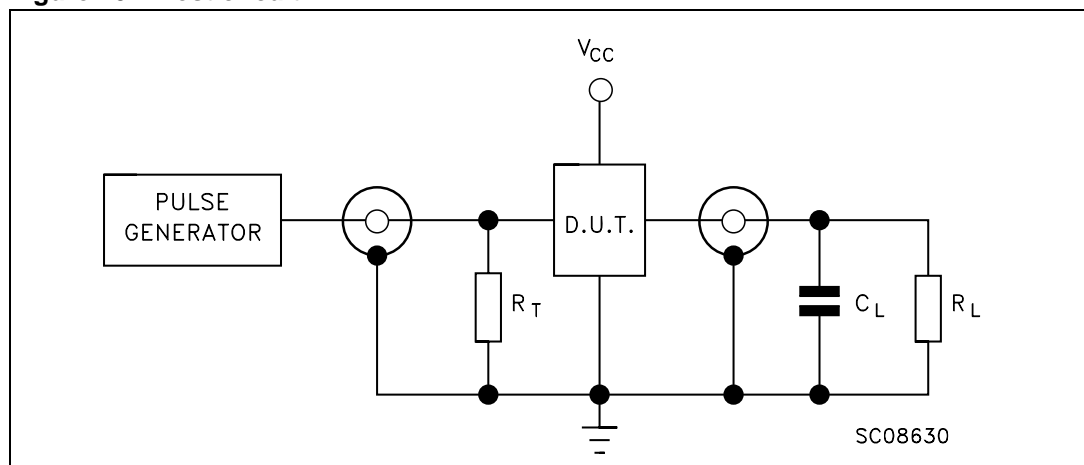

Figure 10. Test circuit



1. $C_L = 5/35$ pF or equivalent: (includes jig capacitance)
2. $R_L = 50 \Omega$ or equivalent
3. $R_T = Z_{OUT}$ of pulse generator (typically 50Ω)

Figure 11. Break-before-make time delay

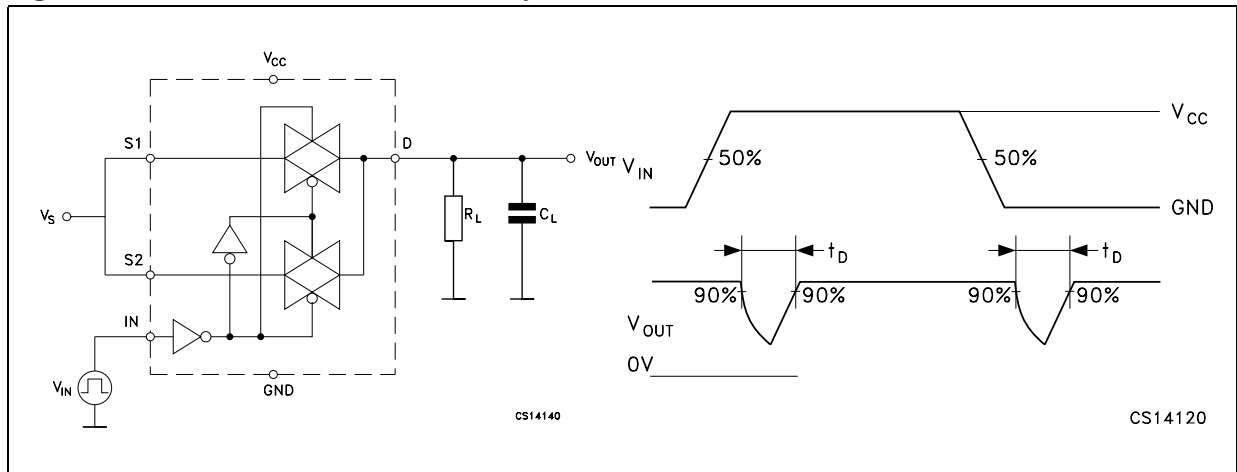

Figure 12. Switching time and charge injection
 ($V_{GEN} = 0\text{ V}$, $R_{GEN} = 0\ \Omega$, $R_L = 1\text{ M}\Omega$, $C_L = 100\text{ pF}$)

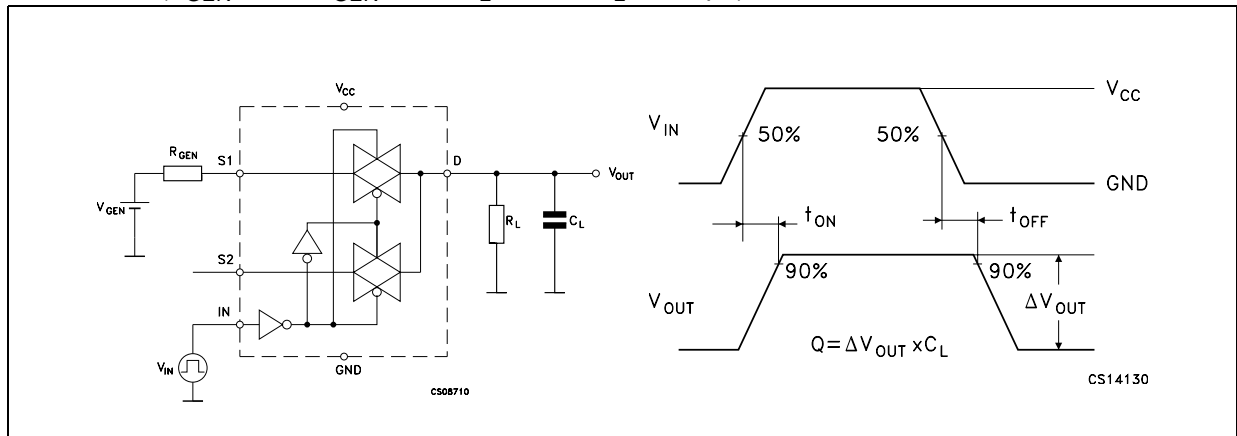
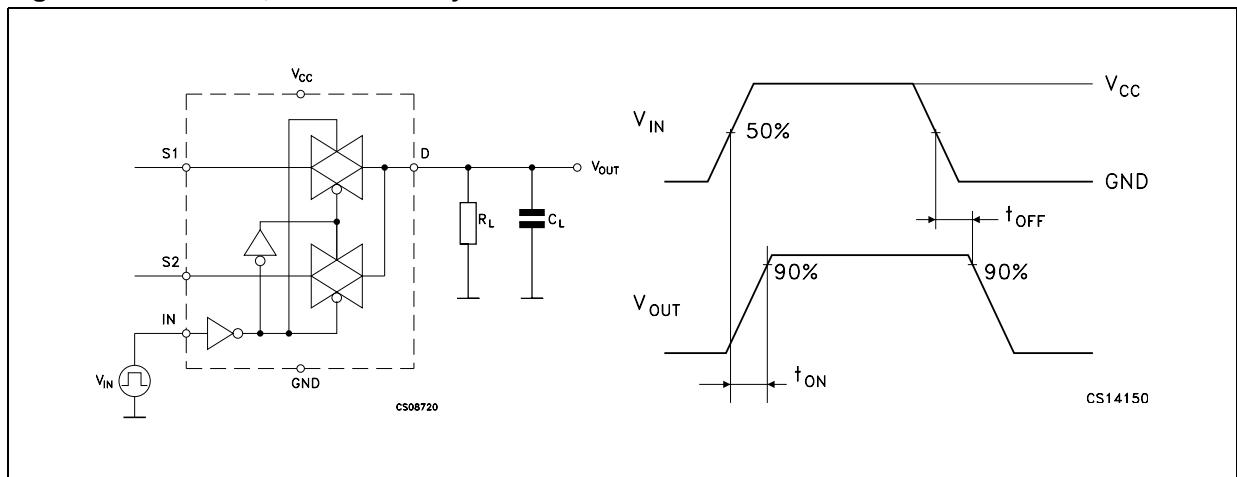

Figure 13. Turn ON, turn OFF delay time



6 Package mechanical data

In order to meet environmental requirements, ST offers these devices in ECOPACK[®] packages. These packages have a Lead-free second level interconnect. The category of second Level Interconnect is marked on the package and on the inner box label, in compliance with JEDEC Standard JESD97. The maximum ratings related to soldering conditions are also marked on the inner box label. ECOPACK is an ST trademark. ECOPACK specifications are available at: www.st.com.

Figure 14. Flip-Chip6 package outline

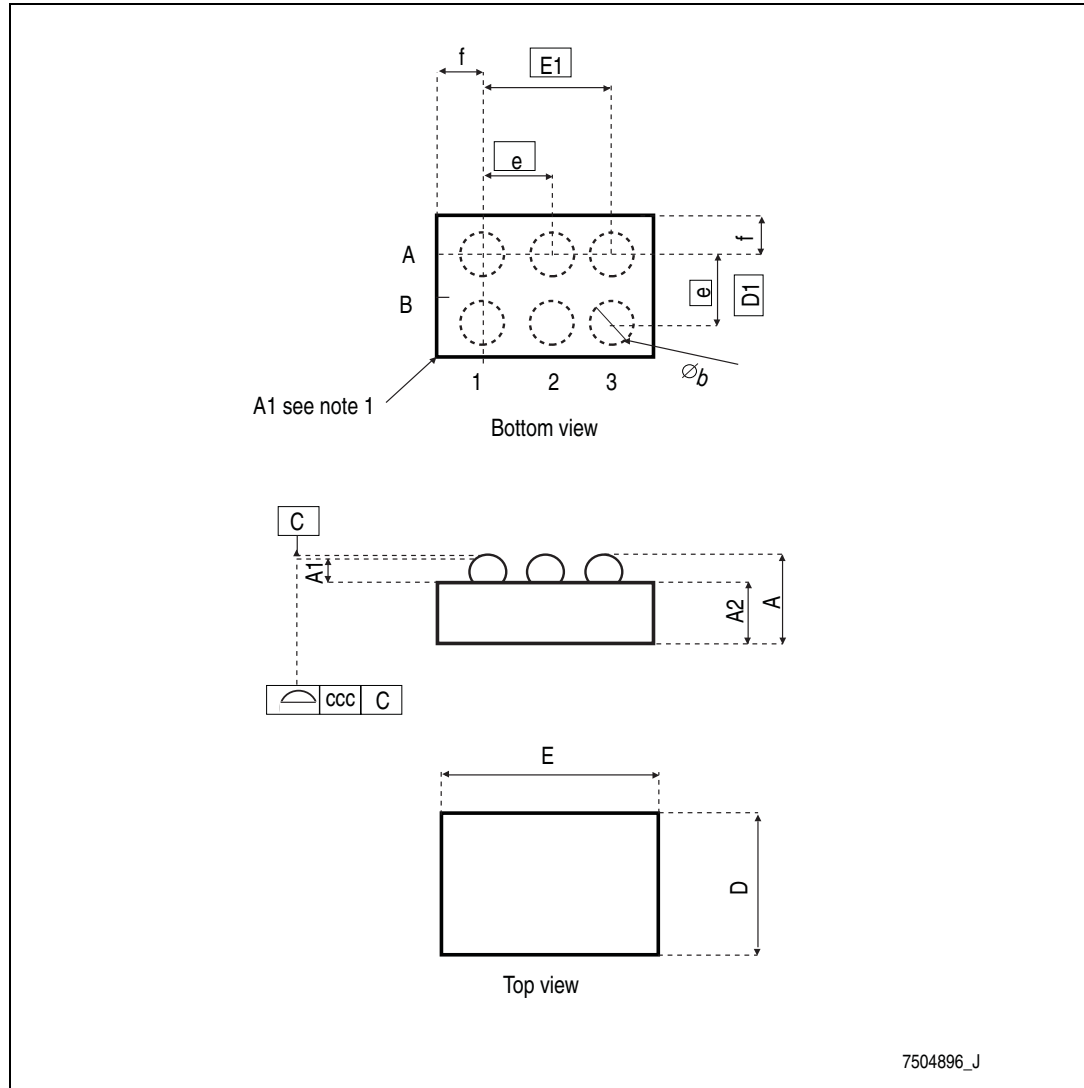

1. The terminal pin 1 on the bumps side is identified by a distinguishing feature (for instance by a circular "clear area" - typically 0.1mm diameter). The terminal pin 1 on the backside of the product is identified by a distinguishing feature (for instance by a circular "dot" - typically 0.5 mm diameter).
2. Drawing not to scale.

Table 10. Flip-Chip6 mechanical data

Symbol	millimeters		
	Min	Typ	Max
A	0.545	0.6	0.655
A1	0.17	0.2	0.23
A2	0.375	0.4	0.425
b	0.23	0.255	0.28
D	0.813	0.828	0.843
D1	0.39	0.4	0.41
E	1.213	1.228	1.243
E1	0.79	0.8	0.81
e	0.36	0.4	0.44
f	0.204	0.214	0.224
ccc		0.05	

Figure 15. Footprint recommendation

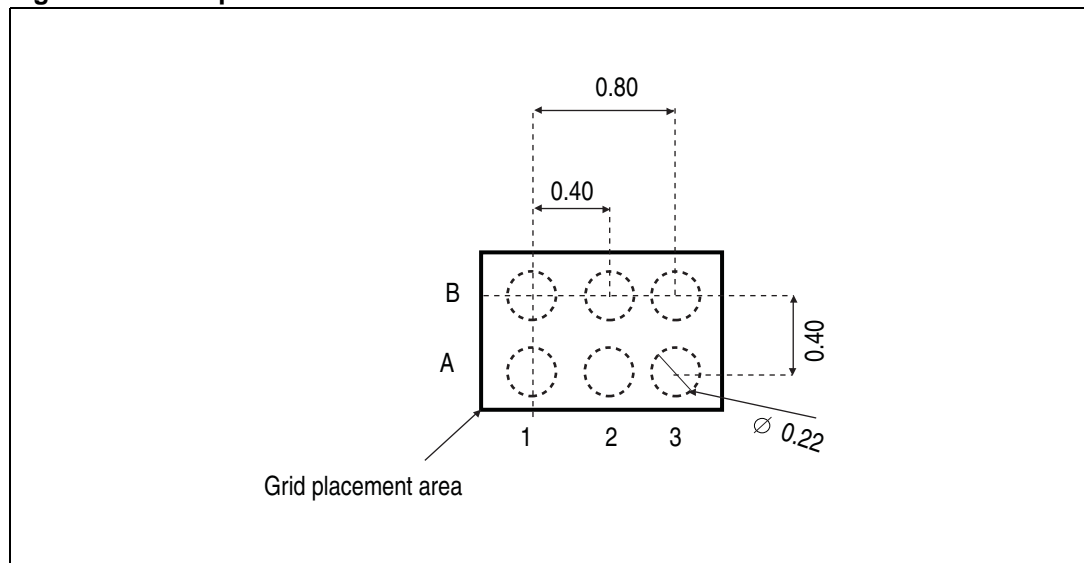

Figure 16. Flip-Chip6 marking

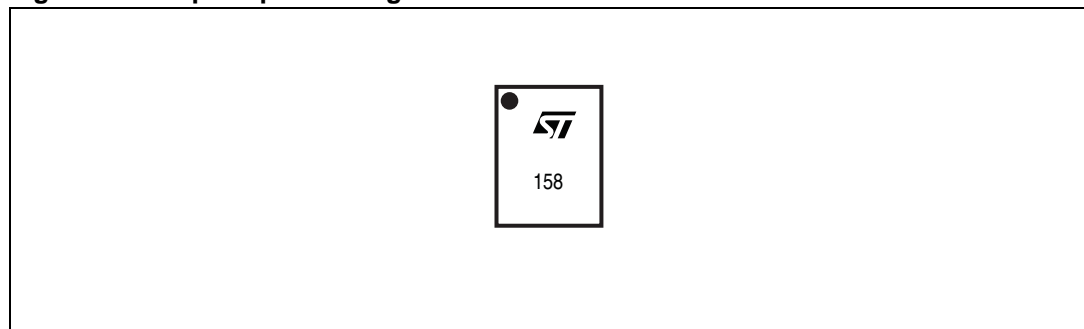

Figure 17. Flip-Chip6 tape specification

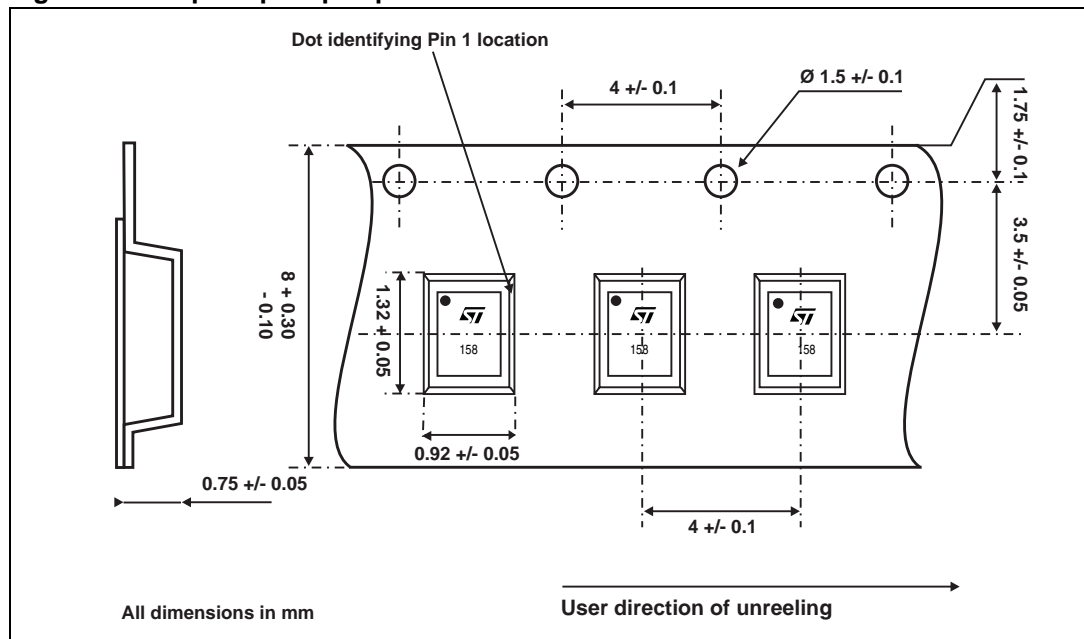
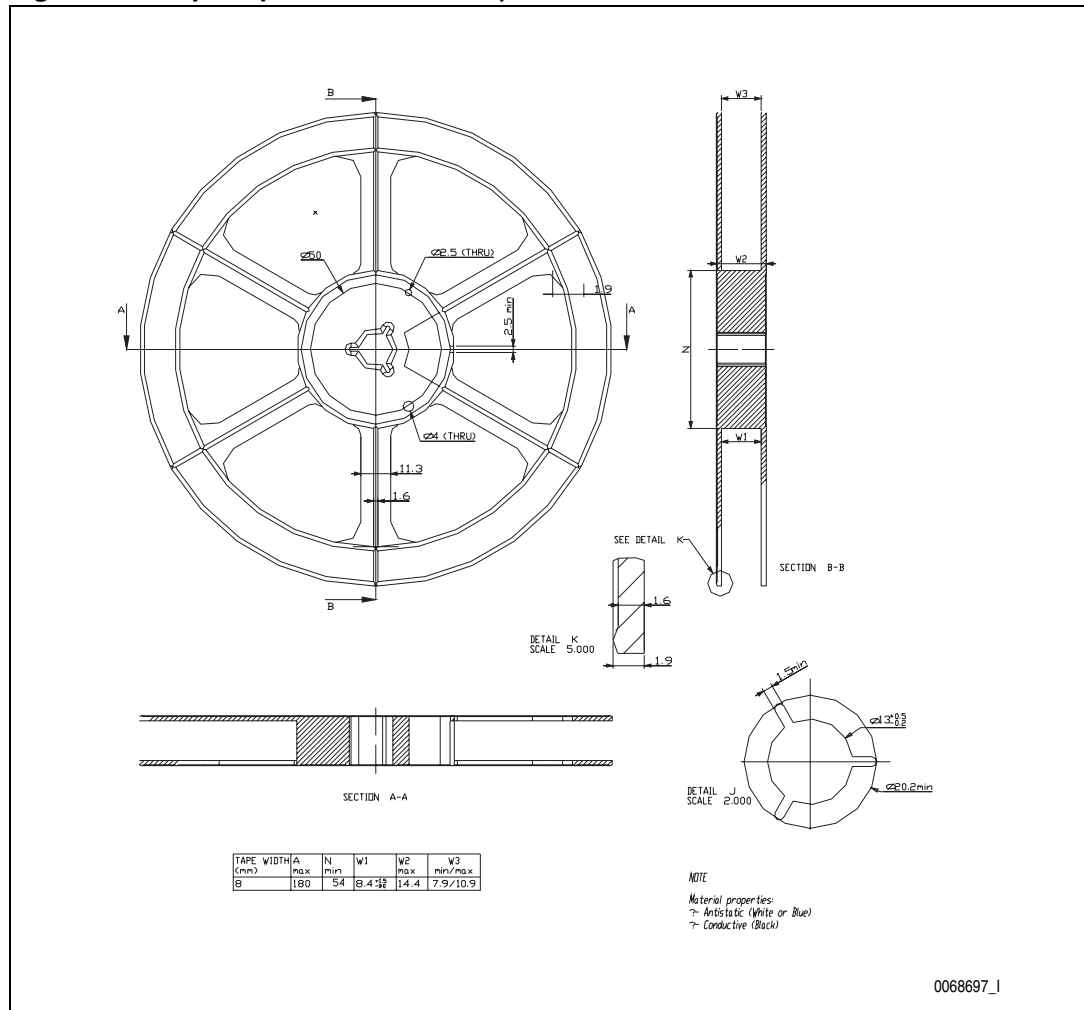

Figure 18. Flip-Chip6 reel information)



0068697_1

7 Revision history

Table 11. Document revision history

Date	Revision	Changes
12-Nov-2007	1	Initial release.

Please Read Carefully:

Information in this document is provided solely in connection with ST products. STMicroelectronics NV and its subsidiaries ("ST") reserve the right to make changes, corrections, modifications or improvements, to this document, and the products and services described herein at any time, without notice.

All ST products are sold pursuant to ST's terms and conditions of sale.

Purchasers are solely responsible for the choice, selection and use of the ST products and services described herein, and ST assumes no liability whatsoever relating to the choice, selection or use of the ST products and services described herein.

No license, express or implied, by estoppel or otherwise, to any intellectual property rights is granted under this document. If any part of this document refers to any third party products or services it shall not be deemed a license grant by ST for the use of such third party products or services, or any intellectual property contained therein or considered as a warranty covering the use in any manner whatsoever of such third party products or services or any intellectual property contained therein.

UNLESS OTHERWISE SET FORTH IN ST'S TERMS AND CONDITIONS OF SALE ST DISCLAIMS ANY EXPRESS OR IMPLIED WARRANTY WITH RESPECT TO THE USE AND/OR SALE OF ST PRODUCTS INCLUDING WITHOUT LIMITATION IMPLIED WARRANTIES OF MERCHANTABILITY, FITNESS FOR A PARTICULAR PURPOSE (AND THEIR EQUIVALENTS UNDER THE LAWS OF ANY JURISDICTION), OR INFRINGEMENT OF ANY PATENT, COPYRIGHT OR OTHER INTELLECTUAL PROPERTY RIGHT.

UNLESS EXPRESSLY APPROVED IN WRITING BY AN AUTHORIZED ST REPRESENTATIVE, ST PRODUCTS ARE NOT RECOMMENDED, AUTHORIZED OR WARRANTED FOR USE IN MILITARY, AIR CRAFT, SPACE, LIFE SAVING, OR LIFE SUSTAINING APPLICATIONS, NOR IN PRODUCTS OR SYSTEMS WHERE FAILURE OR MALFUNCTION MAY RESULT IN PERSONAL INJURY, DEATH, OR SEVERE PROPERTY OR ENVIRONMENTAL DAMAGE. ST PRODUCTS WHICH ARE NOT SPECIFIED AS "AUTOMOTIVE GRADE" MAY ONLY BE USED IN AUTOMOTIVE APPLICATIONS AT USER'S OWN RISK.

Resale of ST products with provisions different from the statements and/or technical features set forth in this document shall immediately void any warranty granted by ST for the ST product or service described herein and shall not create or extend in any manner whatsoever, any liability of ST.

ST and the ST logo are trademarks or registered trademarks of ST in various countries.

Information in this document supersedes and replaces all information previously supplied.

The ST logo is a registered trademark of STMicroelectronics. All other names are the property of their respective owners.

© 2007 STMicroelectronics - All rights reserved

STMicroelectronics group of companies

Australia - Belgium - Brazil - Canada - China - Czech Republic - Finland - France - Germany - Hong Kong - India - Israel - Italy - Japan - Malaysia - Malta - Morocco - Singapore - Spain - Sweden - Switzerland - United Kingdom - United States of America

www.st.com